



Commander MTS SUSPENSION SYSTEM INSTALLATION INSTRUCTIONS

PARTS INCLUDED:

- | | |
|----------------------------|--------------------------------|
| 2 - FRONT UPPER A-ARMS | 2 - REAR TRAILING ARMS |
| 2 - FRONT LOWER A-ARMS | 2 - 10MM x 55MM BOLTS |
| 4 - COTTER PINS | 2 - 10MM NYLON LOCK NUTS |
| 2 - 12MM JAM NUTS | 4 - INNER PIVOT TUBES |
| 2 - TIE ROD EXTENDERS | 1 - REAR BRAKE LINE KIT |
| 8- FLANGED DELRON BUSHINGS | 1- BRAKE LINE JUNCTION BLOCK |
| 4- DELRON CASTER SPACERS | 1 - AXLE KIT, WITH BOOT STRAPS |
| 6 - GREASE FITTINGS | 1 - AXLE KIT INSTRUCTIONS |
| 3 - BEARING REMOVAL TOOLS | |

TOOLS NEEDED:

- Floor jack and/or jack stands
- 15mm wrench and socket
- 16mm socket
- 17mm wrench and socket
- 19mm socket
- 3/8 ratchet
- bearing press (can use hammer if needed)
- Large hammer and dead blow hammer
- Bench mounted vice
- 5mm Allen wrench or socket
- High quality water proof grease w/ gun
- 12mm wrench or socket
- 10mm wrench and socket
- 8mm socket
- 17mm deep socket
- External snap ring pliers
- Needle nose pliers
- Diagonal pliers (cutters)
- Impact wrench or large breaker bar
- 27mm socket
- 7/32 drill bit and drill
- Differential Fluid
- Brake Fluid
- Brake Bleeder system
- Blue threadlocker

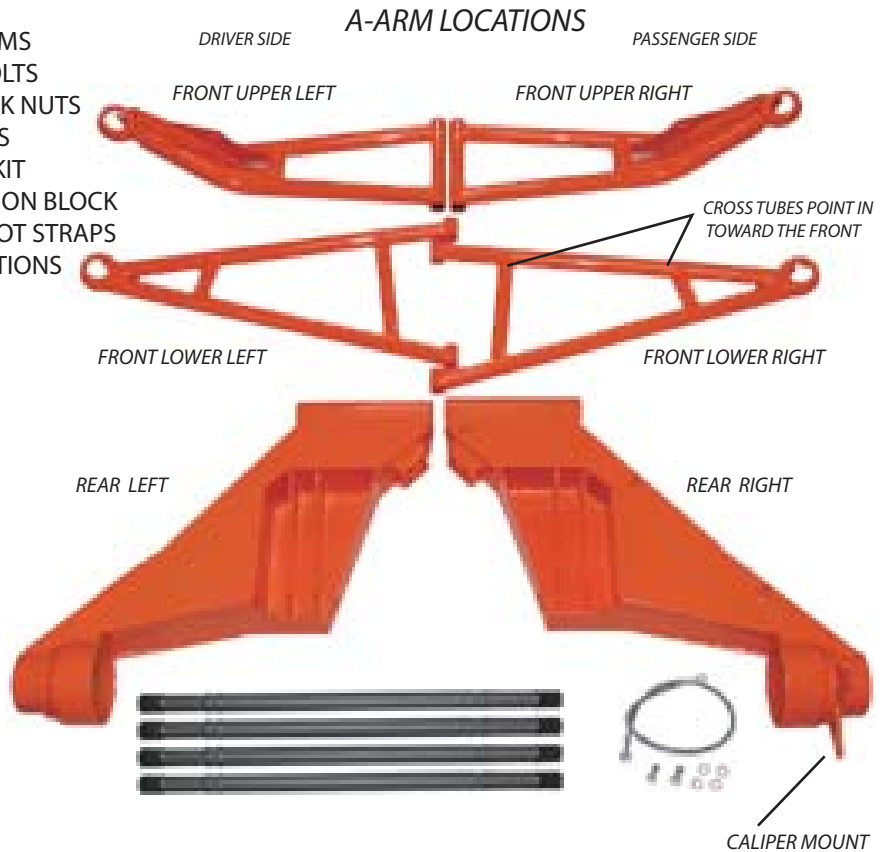

REAR FENDER CUT OUT



FRONT BUMPER CUT

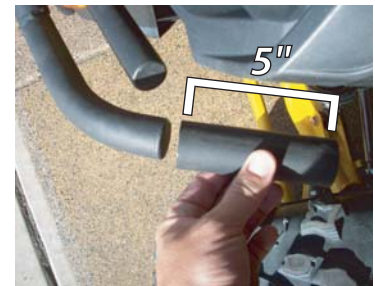

BEFORE YOU START:

The installation of this kit is going to take the better part of a day for an installer that is mechanically inclined. Before you get started, please know that there will be some minor fender trimming in the rear so the tires will not rub at full compression, as well as cutting 5" off the very front bumper tubes of your XT and X versions. There are some large bearings that have press fitments on the trailing arms, and we recommend a bearing press be used for removal and installation. The factory shocks will bolt on, but will leave a lot to be desired in terms of performance. We highly recommend aftermarket shocks that have been built specifically for the Lone Star Racing MTS A-arm Kit. Depending on the Axle Kit you specified, please see the supplement instructions on how to properly install your new axles. The following pages will outline how to install your new MTS A-Arm kit.

CLEANING/ MAINTAINING:

Use soap and water to clean, taking care not to use high pressure pointed at the pivot points. You will want to periodically grease the pivot points with fresh grease using the supplied grease fittings. You will want to periodically check all hardware for tightness.



Commander *MTS* SUSPENSION SYSTEM INSTALLATION INSTRUCTIONS

FRONT SUSPENSION

1. The first thing you need to do is jack up the front end of your Commander and rest it securely on jack stands. Make sure the UTV is very stable once you have the tires off the ground, as you are going to be applying significant force to remove and install hardware.
2. Remove the front wheels using a 17mm socket and impact wrench.
3. Remove the cotter pins and large axle nuts with the 27mm socket and impact wrench. Make sure to not damage the cotter pins, as they need to be re-used.
4. Remove the brake calipers using a 15mm wrench or socket. Remove the brake line clamps on each front spindle.
5. Pull off the wheel hubs.
6. Remove the cotter pins from the ball joint studs and the tie rod studs. Don't worry about saving these, as we have included new ones for final installation.
7. Loosen the castle nuts from the upper ball joints using a 19mm wrench or socket. Loosen them a few complete turns, but do not remove. Loosen the jam nut, then castle nut, and remove the tie-rod end from the spindle. You will need a decent sized hammer to remove the joints from the spindles. Do not use a fork style ball joint remover unless you have new joints to replace the boots that will get torn. We recommend hitting the side of the spindle with a lot of force to jar loose the joint as shown in Fig. #1. If you have a ball joint puller you can use it, but it isn't necessary. While hitting the spindle, use some force pulling the spindle down to separate the joint. It might take several powerful blows to jar it loose. To remove the lower joint, use a 15mm socket and wrench to remove the cross bolt.
8. You should be able to remove the spindle from the a-arms and slide it off of the outer axle shaft stub.
9. Let the lower a-arms drop towards the floor and grasp the axle with a quick pulling motion to slide the entire axle assembly from the differential. It might take some force to pull the axles from the differential, but they should pop out by hand. The differential will leak a small amount of fluid once the axles are removed, so be prepared.
10. Now you can remove the bolts that hold the shocks to the chassis and a-arms, and remove the bolts that hold the a-arms to the chassis. You will be re-using these bolts and nuts for installation of the new a-arms. You will need to remove the radiator mounting bolts, (and winch if so equipped) and pull the radiator to the side to remove the upper a-arm bolts. There is enough stretch in the hoses so you do not need to disconnect or drain the coolant. You will have to pull the lower hose through the frame to get enough clearance. It will take some wiggling. Make sure to not damage the radiator fins.
11. Next you need to drill out the rivets that hold the brake lines to the a-arms using the 7/32" drill bit so the lines are free from the a-arms.
12. You will need to remove the OEM ball joints from the OEM a-arms to use in your new a-arms. You can use a bench mounted vice or a press to remove and install the joints. They get pressed into the new a-arms just like they were positioned in the OEM a-arms. Make sure the snap rings seat fully to make sure the joints can't come out once they are installed.

Fig. 1



Removal of Ball Joint





Commander MTS SUSPENSION SYSTEM INSTALLATION INSTRUCTIONS

FRONT SUSPENSION con't.

13. Now you need to remove all of the pivot hardware from the upper a-arms. You can discard the thin steel dust caps on each end, as they are useless, and just make installation more difficult.
14. Install the pivot bushings into the new LSR a-arms, and install the center tubes.
15. The lower a-arms are already assembled on the pivot areas. They have been set up for a default caster setting just like OEM. Please see the "Quick Caster" guide below, for details on what the spacers do, and how to change them.
16. Now you can install the axle shaft assemblies back into the differentials, once you have swapped out the axle shafts. If the front diff was rotated, the passenger side splines can rotate internally, allowing the axle to not go in properly. If this happened, rotate the driveshaft until the splines line up inside the diff, so the axle can slide in. Make sure it goes in fully, and seats the spring clips into the grooves.
17. Install the a-arms into the chassis, using the OEM bolts. Tighten hardware to 40 ft lbs. Now is a good time to grease the joints with a grease gun using the zerk fittings provided. The lower a-arms will have the zerk fittings pointing towards the ground.
18. Now, take the spindle, slide the axle stub shaft into the bearing, and attach the upper and lower ball joints to the spindle. Install and tighten the cross bolts, and the upper ball joint nut and washers.
19. Remove the tie rod ends from the tie rod shafts. Install the new tie rod extenders, and thread on the rod ends. Don't worry about the exact distance now, as you will adjust the toe in later. Attach the tie rod end to the spindle.
20. You can now install the wheel hubs, large washer and slotted nut. Use an impact wrench or a large breaker bar to tighten them to approx 150 ft lbs.
21. Install the brake calipers on both sides, and route the lines through the clamps on the a-arms. Make sure the lines don't interfere with turning lock to lock and with the wheels or cv joints while they turn.
22. Install the shocks using the OEM bolts. Make sure if you have the adjustable style, you can reach the rebound adjusters once they are installed.
23. Place the radiator back into position, and push the lower hose back into the frame. Tighten the mounting bolts, and install the winch if equipped.
24. Install the wheels using your 17mm impact.

QUICK CASTER SET UP DETAILS FRONT LOWER A-ARMS WHAT DOES IT DO?

Quick Caster is a feature that lets you adjust how easily your vehicle will steer. The more caster you add, the stiffer the steering wheel will turn. The less caster you add, the easier the steering wheel will turn. To adjust the settings, there are 2 black delrin spacers that are supplied to be installed on each of the **front lower** a-arms. The locations of the spacers dictate the caster setting. Lone Star Racing is the originator of this feature, and currently, no other suspension kit has this feature!

DRIVING TYPE

HIGH SPEED DESERT RACING, DUNES

GENERAL RIDING, SHORT COURSE RACING, TIGHTER TRAILS

LOWER SPEED, TIGHT TRAILS, SHORT COURSE RACING
CRUISING THE NEIGHBORHOOD

HIGH POSITION

If you want the most control at high speeds over rough terrain to keep the car going in a straight line, and lessen the chance of the steering wheel popping out of your hands, you want to set the caster in the high position.

MEDIUM POSITION (like stock)

If you want a little easier steering, and don't need as much control at high speeds over rough terrain, you want to set the caster in the medium position. This position will be used by the majority of riders.

LOW POSITION

If you want the easiest steering possible with the most maneuverability, you want to set the caster in the low position.

Please note, these are just suggestions, each driver will have different preferences. There is no right or wrong here, its all in how you want your car to handle.

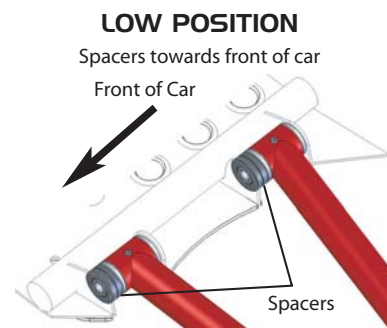
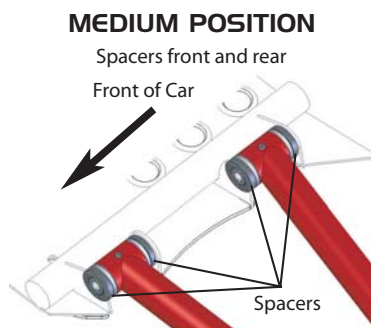
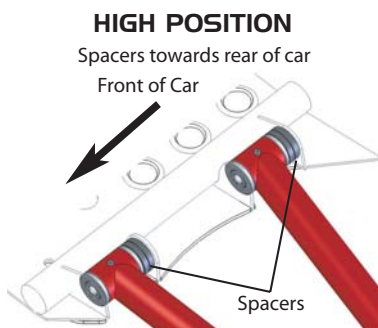



Commander *MTS*

SUSPENSION SYSTEM

INSTALLATION INSTRUCTIONS

REAR SUSPENSION

1. Jack up the rear end of your Commander and rest it securely on jack stands. Make sure the UTV is very stable once you have the tires off the ground, as you are going to be applying significant force to remove and install hardware.
2. Remove the wheels using a 17mm socket and impact wrench.
3. Remove the cotter pins and large axle nuts with the 27mm socket and impact wrench. Make sure to not damage the cotter pins, as they need to be re-used.
4. Remove the brake caliper using a 15mm wrench or socket. Drill out the rivets that hold the brake line to the trailing arm.
5. Pull off the wheel hubs.
6. Remove the sway bar using a 15mm socket, and then remove the shocks.
7. Remove the trailing arm mounting bolts, and take the trailing arms to a bench. You need to remove the seal spacers, seals, bearings, and center tube from the pivot side of the trailing arm. We included some press tools to make it easier. There will be skinny one that you need to use to remove the pivot bearings and center tube. It should fit inside the bearings, and into the center tube.
8. Press out the bearings on both sides.
9. Using a small screwdriver or pick, remove the retaining ring on the wheel hub bearing, and use the large press tool to remove the bearing from the trailing arm. You might need to use some penetrating oil, or heat to help the bearings come out easier.
10. Reinstall the bearings into the new trailing arms in the same locations you removed them. Make sure to install the seal spacers on the pivot side.
11. Reinstall the retaining ring into the wheel hub side bearing.
12. Remove the axles from the rear diff, and swap out the shafts as outlined in the supplement instructions. Install the new axle shaft assemblies into the differential with a quick motion and make sure they are fully seated.
13. Now that the trailing arms are fully assembled with the new bearings, it is time to install them back into the car. You will need to simultaneously insert the axle stub into the bearing of the trailing arm, while locating the trailing arm into the mounts on the chassis. Make sure you install the bolt from the inside out, or the sway bar will not be able to be installed. Tighten up the bolt to 65 ft lbs. Next, you can install the shocks. You will need to use the new supplied 10mm bolts on the trailing arm, as the mounts are thicker.
14. Now it is time to install the sway bar. Locate the sway bar to the new mounting blocks, and get at least one bolt started. Move to the other side, and start another bolt. You might have to use a dead blow hammer, pushing the sway bar towards the front of the car to align the bolt holes. Now you can install the rest of the bolts using some blue threadlocker. You will need to tighten the bolts multiple times, as the bar becomes seated with the trailing arms. Make sure all the bolts are tightened evenly.
15. Install the rear wheel hubs, and tighten the large castle nuts to 150 ft lbs, and install the cotter pins.
16. Now you will need to remove the brake line from the caliper. Install the caliper on the trailing arm.
17. Using the brake line kit, and junction block, attach the new line to the caliper and the junction block. Then attach the original line to the other side of the junction block. Make sure you install a copper crush washer on both sides of the banjo bolts. Then using the 6mm bolt, attach the junction block to the trailing arm mounting boss, and install the line into the clamps that are welded to the trailing arm. Make sure the line does not touch any rotating parts, and it is away from the wheel and shock.
18. Now you will need to bleed the air from the rear brake line system using a bleeder and new brake fluid.
19. Install the wheels, and lug nuts, lower the car to the ground.
20. Set up the front toe in adjusting the tie rods. A good rule of thumb is to have about an 1/8" to 1/4" of toe measured at the wheel edge. Make sure both tie rods are the same length, so your steering wheel will be centered.
21. Take the car for a short test drive. Then measure the ride height. You will want to start out in the range of 12", with the rear being slightly lower than the front.
22. Go back through, and tighten all the hardware again, and after you take a decently long ride, then install the cotter pins into the front spindle hardware.

Brake line extension details

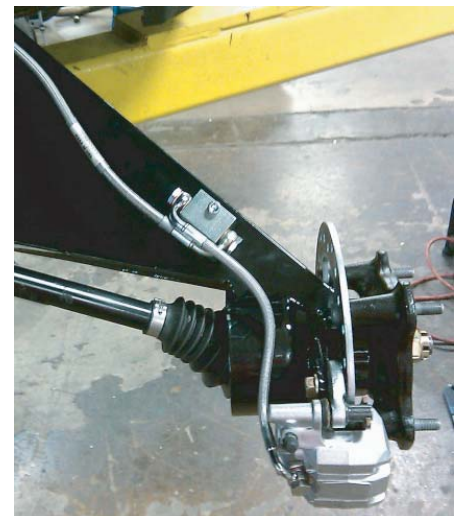



COMMANDER STANDARD AXLE INSTALLATION INSTRUCTIONS

PARTS INCLUDED:

- 2 Front Axle Shafts
- 2 Rear Axle Shafts
- 16 Long Band Clamps



TOOLS NEEDED:

- Needle Nose Pliers
- Small Flat Blade Screw Driver
- Diagonal Cutters
- Moly CV Joint Grease
- Large Dead Blow Hammer
- Bench Mounted Vice
- Band Clamp Tightening Tool
- Nytrile Gloves
- Rags

Axle Shaft Sizes:

X-TR +6 A-Arms **M-TS** +4 A-Arms

Front Axle Shaft	24.125"	22.125"
Rear Axle Shaft	26"	24"

Shown in Overall Lengths

1. Axle Shaft Removal:

First, you need to remove the front and rear hub and spindle assemblies from the a-arms, as well as the trailing arms. To remove the axle from the differential, all that is needed is a swift pull on the shaft straight out. You can use the slide motion of the CV joint to assist. It should only take a couple of quick thrusts to pop them out of the differentials by hand.

2. Axle Shaft Disassembly:

Work in a clean area with lots of rags handy, as this will be a messy job. Take care not to get any contaminants in the joints to aid in reassembly. Now that the axle assemblies are removed, you will want to clean them thoroughly using a degreaser and rags. Remove all dirt and sand etc. before you take them apart. You will need to remove the boot clamps by using a small flat blade screw driver to open them up or cut them with diagonal pliers. Pull the boots away from the CV joint. The CV needs to be taken apart using a vice and hammer as shown in Fig. 1. Grasp the joint, and hit the CV joint as shown. It will take a decent amount of force to pop them loose. Remove the small clip as shown in Fig. 2. Slide the boot off of the shaft. Repeat this process for the other side. Take note, as each end of the axle is different, and it is important that they go together the correct way. All axles use the same system to remove. But please note, not all parts are the same, so we recommend doing them one at a time. The axle shafts are the same left to right, but the differential side cv joints are not the same.

Fig 1



Fig 2



Wheel Hub End



Axle Shaft Circlip Boot Wheel Stub

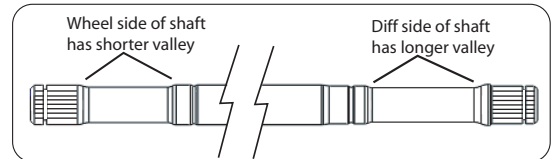

3. Axle Shaft Reassembly:

You will need to find the right length axle shaft for the location you are working on, using the chart above. Pick an end to start on using the pictures above as a guide. Slide the boot onto the axle shaft. Then install the small circlip into the groove using needle nose pliers. Take the wheel side stub end, and rest it on a table with the joint facing up. Slide the shaft into the CV joint, and make sure it is pointing straight up. Tap on the end of the axle to compress the snap ring, and it will fall into place. Make sure the axle is fully seated in the CV joint by trying to pull it back out. Then, on the other side, slide on the other boot, then repeat the process. Now you can pack the CV joints with high quality moly CV joint grease. Now slide the boots into position. To install the new straps, insert the thin end into the slot of the other end, and pull it through similar to a zip tie. Position the strap around the groove on the boot and make sure it is even. Using the installation tool, put tension on the strap, and rotate tool over the buckle. Use the tool to cut the strap. Fold over the strap so the strap is flat. Then fold over the 2 small ears to hold the strap. You can go to any automotive parts store and purchase or rent a cv boot strap tightening tool.

For more help go to YouTube.com for a video:
<http://www.youtube.com/watch?v=lxqsKbXrYyY>



You can rent these tension type tools from local auto parts stores to help install the cv boot clamps

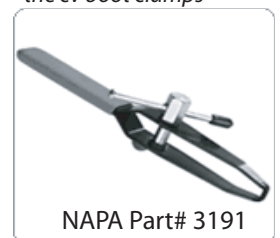

NAPA Part# 3191

4. Axle Shaft Installation:

Place the differential end of the shaft into the differential. Make sure the splines are lined up, and that it is partially seated into the differential. You can use a dead blow hammer to tap the shaft in until it is fully seated, or just push it in by hand.